



US007952540B2

(12) **United States Patent**  
**Lee**

(10) **Patent No.:** **US 7,952,540 B2**  
(45) **Date of Patent:** **\*May 31, 2011**

(54) **ORGANIC LIGHT EMITTING DISPLAY  
DEVICE AND DRIVING METHOD THEREOF**

(75) Inventor: **Wook Lee, Suwon (KR)**

(73) Assignee: **Samsung Mobile Display Co., Ltd.,  
Yongin (KR)**

(\* ) Notice: Subject to any disclaimer, the term of this patent is extended or adjusted under 35 U.S.C. 154(b) by 888 days.

This patent is subject to a terminal disclaimer.

(21) Appl. No.: **11/861,116**

(22) Filed: **Sep. 25, 2007**

(65) **Prior Publication Data**

US 2008/0186263 A1 Aug. 7, 2008

(30) **Foreign Application Priority Data**

Feb. 5, 2007 (KR) ..... 10-2007-0011787

(51) **Int. Cl.**  
**G09G 3/30** (2006.01)

(52) **U.S. Cl.** ..... 345/76; 345/82; 345/77

(58) **Field of Classification Search** ..... 345/36,  
345/39, 42, 45-48, 50-51, 76-77, 81-84,  
345/87-88, 204, 207, 211-214, 690, 697-698;  
315/169.3

See application file for complete search history.

(56) **References Cited**

**U.S. PATENT DOCUMENTS**

5,754,150 A \* 5/1998 Matsui ..... 345/89  
6,987,787 B1 \* 1/2006 Mick ..... 372/29.021  
7,557,788 B1 \* 7/2009 Orlando et al. .... 345/89  
7,656,383 B2 \* 2/2010 Hedrick ..... 345/102  
7,679,602 B2 \* 3/2010 Owyneung et al. .... 345/156

7,782,279 B2 \* 8/2010 Lee et al. .... 345/82  
7,808,459 B2 \* 10/2010 Lee et al. .... 345/77  
2005/0057191 A1 \* 3/2005 Jo et al. .... 315/291  
2005/0057581 A1 \* 3/2005 Horiuchi et al. .... 345/690  
2006/0125767 A1 6/2006 Kang et al.  
2006/0244387 A1 11/2006 Park et al.

(Continued)

**FOREIGN PATENT DOCUMENTS**

KR 10-2006-0007972 1/2006

(Continued)

**OTHER PUBLICATIONS**

Korean Patent Abstracts, Publication No. 1020060112997, dated Nov. 2, 2006, in the name of Young Jong Park et al.

(Continued)

*Primary Examiner* — Quan-Zhen Wang

*Assistant Examiner* — Mansour M Said

(74) *Attorney, Agent, or Firm* — Christie, Parker & Hale, LLP

(57) **ABSTRACT**

An organic light emitting display device includes a display area including pixels coupled to scan, light emission control, and data lines; a scan driver electrically coupled to the display area through the scan and light emission control lines; a data driver electrically coupled to the display area through the data lines; an optical sensor for generating a sensor signal corresponding to an ambient light brightness; a first luminance control unit for outputting a first luminance control signal (Vc1) for controlling a gamma-corrected gray level voltage of a data signal in accordance with the sensor signal; a second luminance control unit for outputting a second luminance control signal (Vc2) for controlling a width of a light emission control signal in accordance with data of one frame; and a comparator/selector for comparing the first and second luminance control signals to output one of them into the data driver.

**20 Claims, 7 Drawing Sheets**

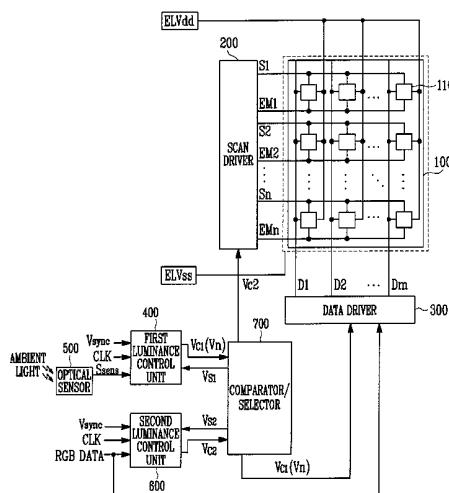

U.S. PATENT DOCUMENTS

2006/0262109	A1	11/2006	Park et al.	
2007/0146302	A1 *	6/2007	Liu et al. ....	345/102
2008/0204438	A1 *	8/2008	Song et al. ....	345/207
2008/0246699	A1 *	10/2008	Oh .....	345/76
2009/0166510	A1 *	7/2009	Park et al. ....	250/205

FOREIGN PATENT DOCUMENTS

KR	10-2006-0112997	11/2006
KR	10-2006-0113009	11/2006

OTHER PUBLICATIONS

Korean Patent Abstracts, Publication No. 1020060113009, dated Nov. 2, 2006, in the name of Jae Sung Lee et al.  
Korean Patent Abstracts, Publication No. 1020060007972 A, Published on Jan. 26, 2006, in the name of Cho et al.  
KIPO Office action dated Feb. 20, 2008, for Korean Patent application 10-2007-0011786, with English translation, noting Korean reference 10-2006-0112997 listed in May 23, 2008 IDS.

\* cited by examiner

FIG. 1

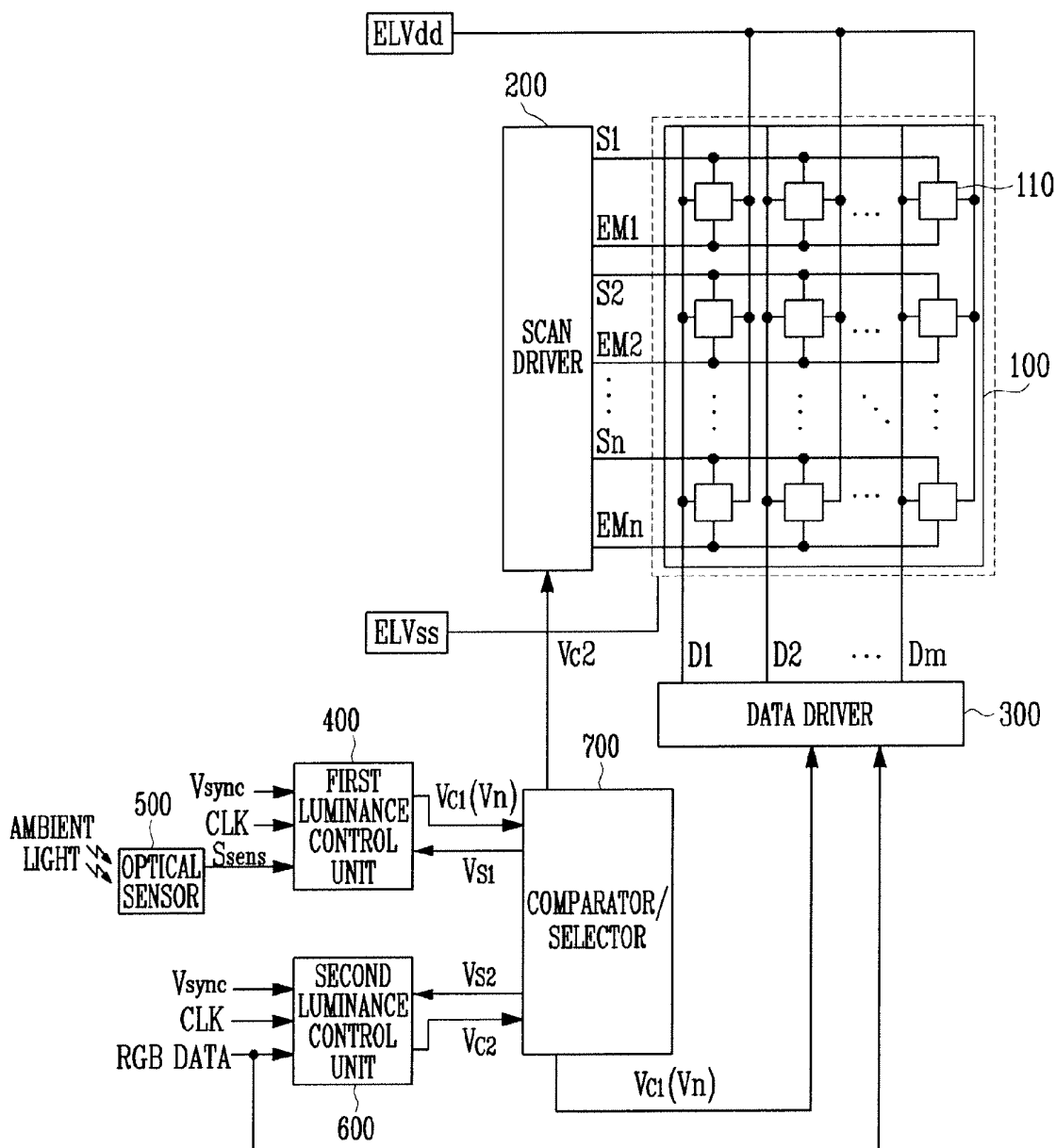

FIG. 2

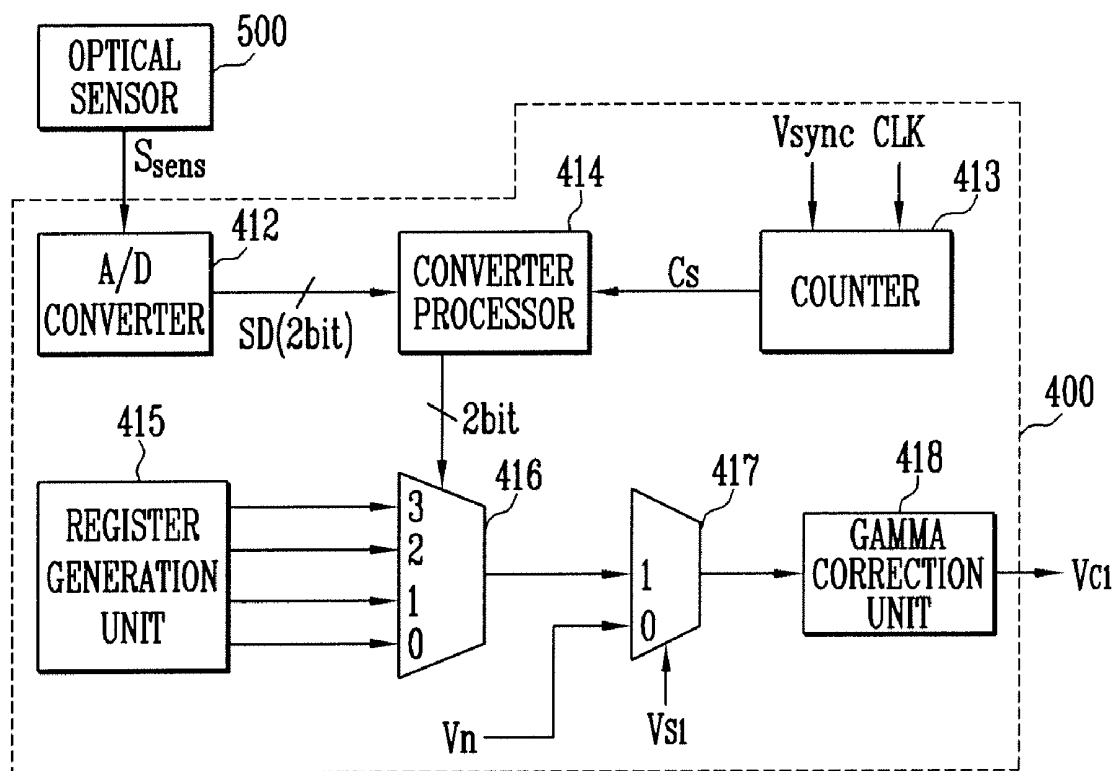

FIG. 3

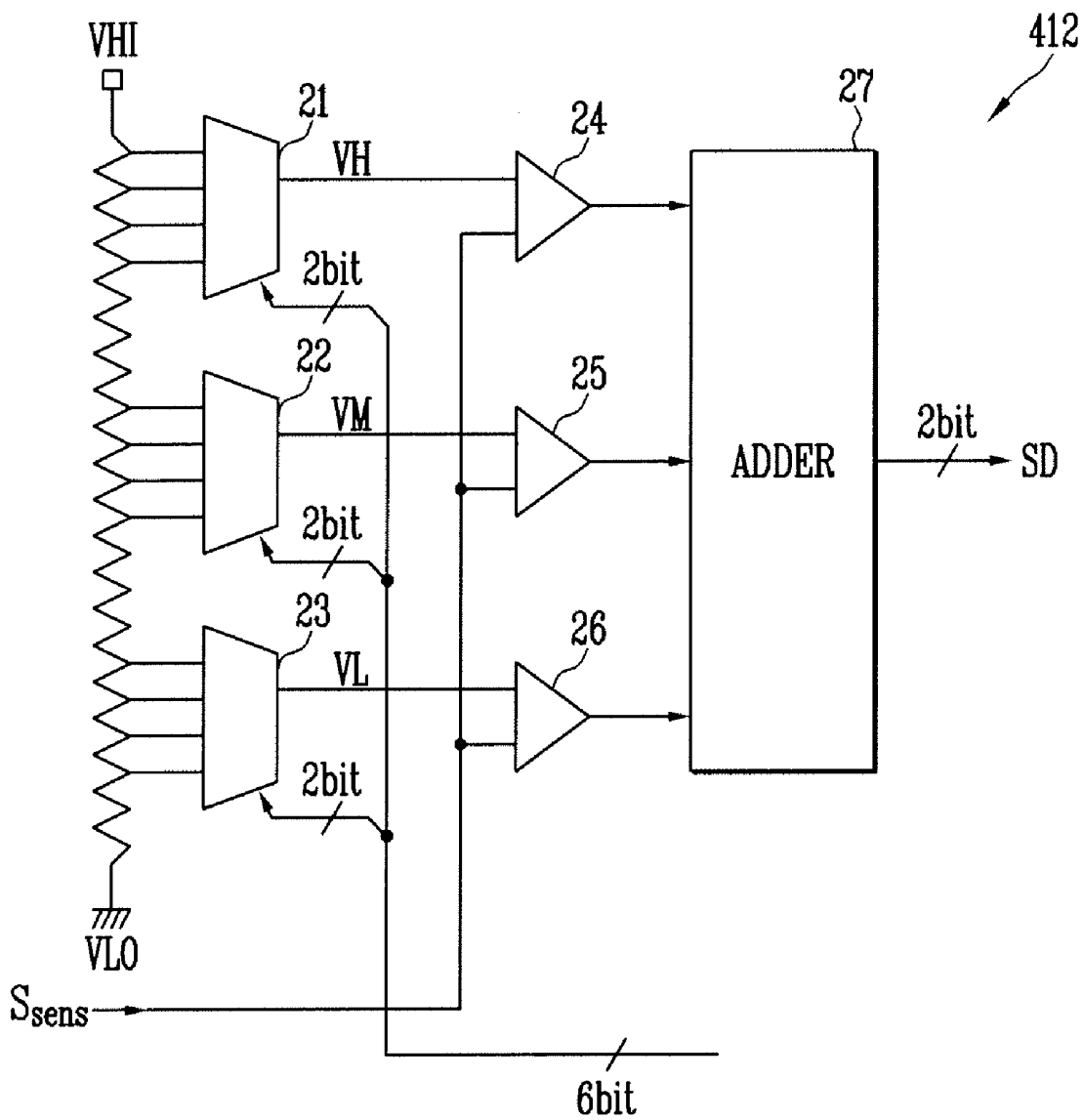

FIG. 4

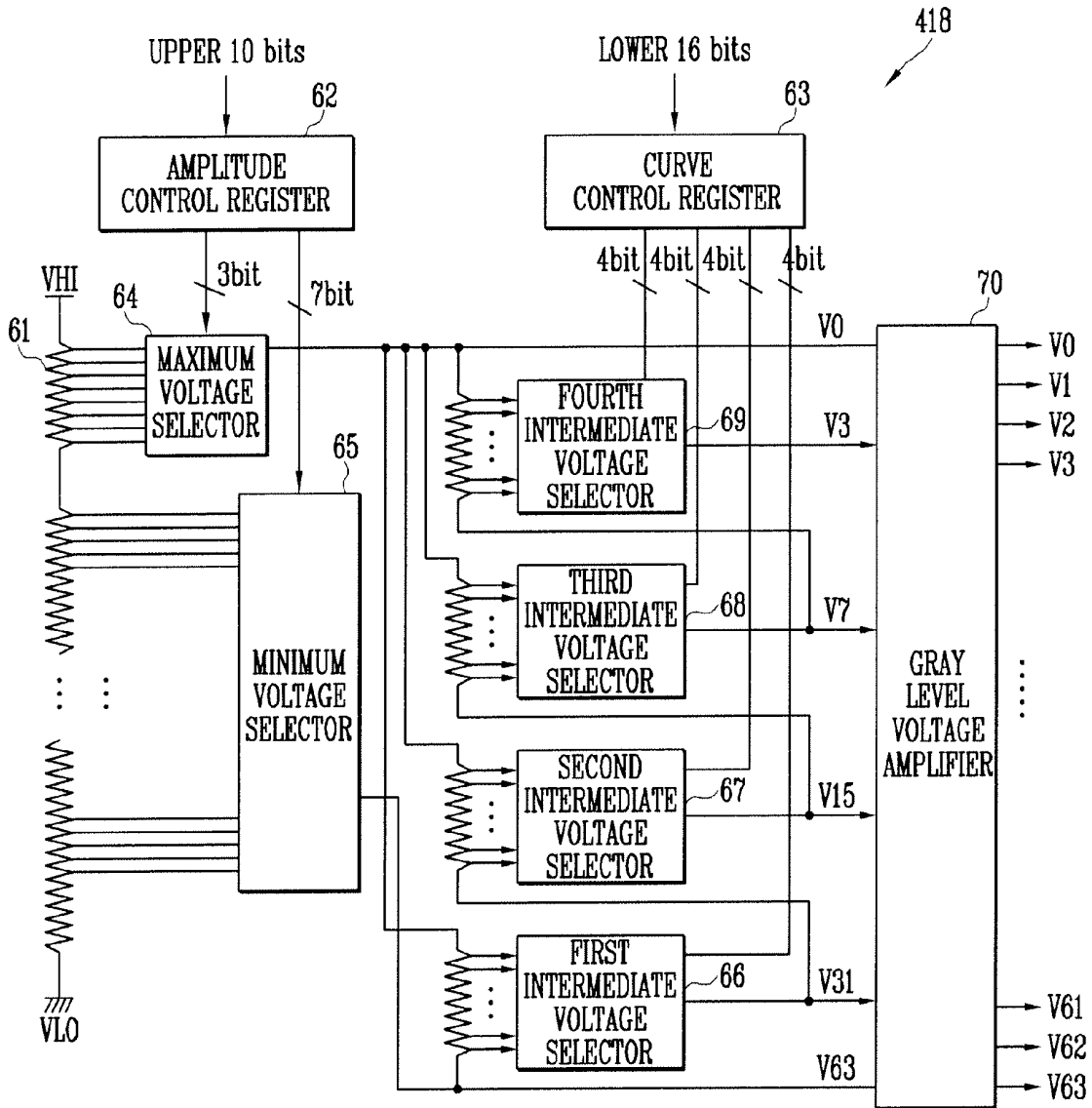

FIG. 5A

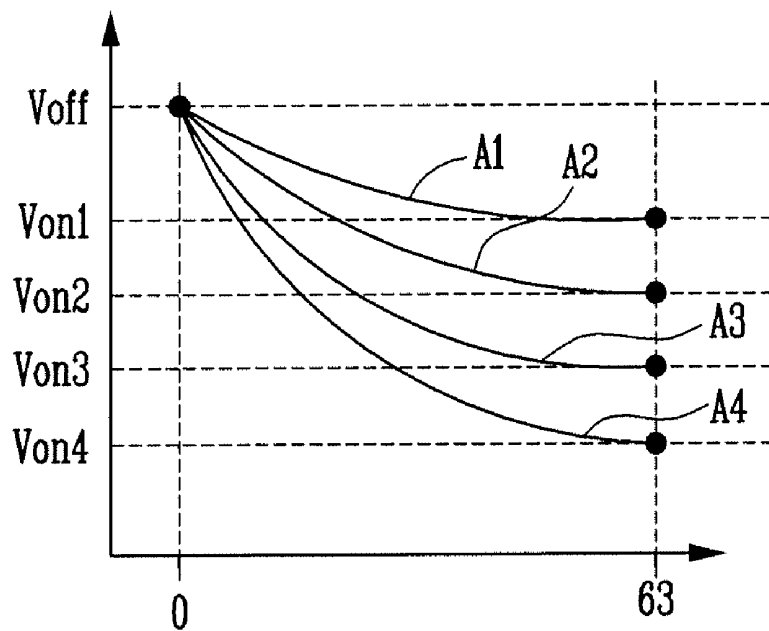

FIG. 5B

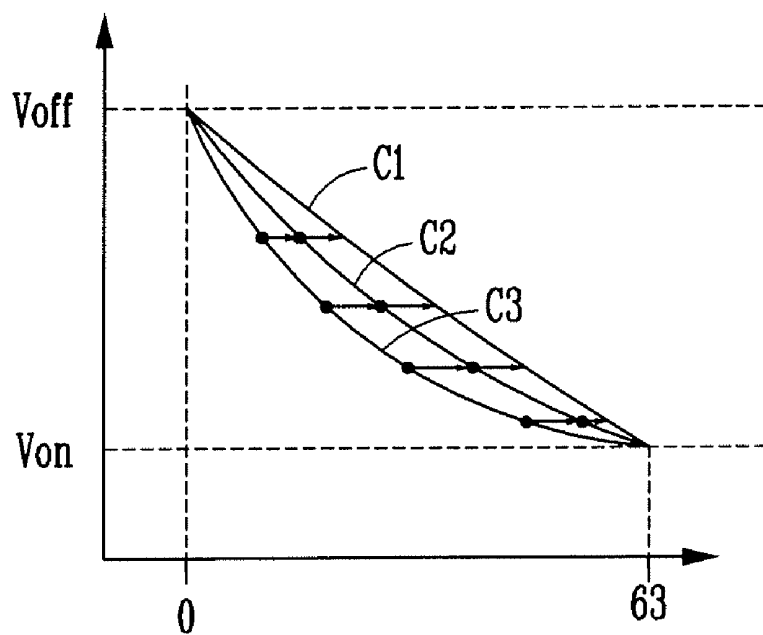
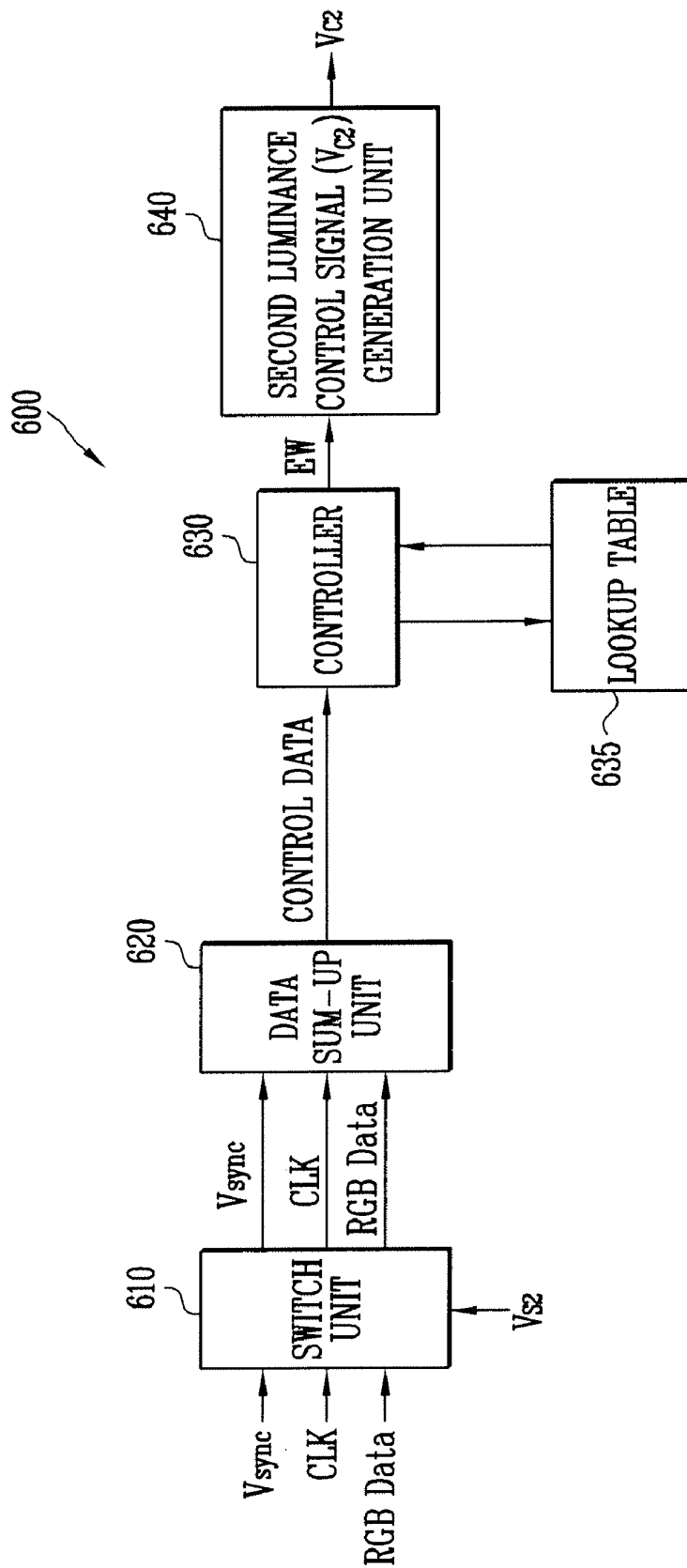

FIG. 6



## FIG. 7

635

UPPER 5-BIT VALUE (CONTROL DATA)	LIGHT EMITTING RATE	LIGHT EMITTING RATIO	LUMINANCE	EW(Hsync)
0	0%	100%	300	325
1	4%	100%	300	325
2	7%	100%	300	325
3	11%	100%	300	325
4	14%	100%	300	325
5	18%	99%	298	322
6	22%	98%	295	320
7	25%	95%	285	309
8	29%	92%	275	298
9	33%	88%	263	284
10	36%	83%	250	271
11	40%	79%	237	257
12	43%	75%	224	243
13	47%	70%	209	226
14	51%	64%	193	209
15	54%	61%	182	197
16	58%	57%	170	184
17	61%	53%	160	173
18	65%	50%	150	163
19	69%	48%	143	155
20	72%	45%	136	147
21	76%	43%	130	141
22	79%	41%	124	134
23	83%	40%	119	128
24	87%	38%	113	122
25	90%	36%	109	118
26	94%	35%	104	113
27	98%	34%	101	109
28	—	—	—	—
29	—	—	—	—
30	—	—	—	—
31	—	—	—	—

## ORGANIC LIGHT EMITTING DISPLAY DEVICE AND DRIVING METHOD THEREOF

### CROSS-REFERENCE TO RELATED APPLICATIONS

This application claims priority to and the benefit of Korean Patent Application No. 10-2007-0011787, filed on Feb. 5, 2007, in the Korean Intellectual Property Office, the entire content of which is incorporated herein by reference.

### BACKGROUND

#### 1. Field of the Invention

The present invention relates to an organic light emitting display device and a driving method thereof.

#### 2. Discussion of Related Art

In recent years, various flat panel displays, which have reduced weight and volume compared to cathode ray tubes, have been developed. In particular, organic light emitting diode display devices have attracted public attention, because the organic light emitting diode display devices have an excellent luminance and color purity since organic compounds are used as a light emission material.

Such an organic light emitting display device is expected to be effectively used for portable display devices, and the like, since it is thin and light-weight and may be driven at a low electric power.

However, conventional organic light emitting display devices emit light with a constant luminance regardless of surrounding brightness, and therefore their visibility is varied according to the surrounding brightness even if an image is displayed with the same gray levels. For example, an image, which is displayed when the surrounding brightness is high, has a reduced visibility, compared to an image displayed when the surrounding brightness is low.

Also, in conventional organic light emitting display devices, the amount of electric current that flows to a display area increases as the number of pixels that emit light during one frame period increases. Further, if there are pixels among the light-emitting pixels, that display high gray levels, a larger amount of electric current flows to the display area, resulting in increased power consumption.

### SUMMARY OF THE INVENTION

Accordingly, one exemplary embodiment of the present invention is an organic light emitting display device capable of controlling a luminance according to brightness of the ambient light and/or data of one frame, reducing power consumption, and also preventing excessive reduction of luminance, and a driving method thereof.

An aspect according to an exemplary embodiment of the present invention is achieved by providing an organic light emitting display device for displaying an image, the organic light emitting display device having a plurality of scan lines, a plurality of light emission control lines and a plurality of data lines. The organic light emitting display device includes a display area including a plurality of pixels coupled to the scan lines, the light emission control lines and the data lines; a scan driver electrically coupled to the display area through the scan lines and the light emission control lines; a data driver electrically coupled to the display area through the data lines; an optical sensor for generating an optical sensor signal corresponding to a brightness of an ambient light; a first luminance control unit for outputting a first luminance control signal for controlling a gamma-corrected gray level volt-

age of a data signal of the image applied to the data lines, in accordance with the optical sensor signal; a second luminance control unit for outputting a second luminance control signal for controlling a width of a light emission control signal applied to the light emission control lines, in accordance with data of one frame of the image; and a comparator/selector for comparing the first luminance control signal with the second luminance control signal to provide the first luminance control signal or the second luminance control signal to the data driver or the scan driver.

The comparator/selector may be adapted to output the first luminance control signal or the second luminance control signal in accordance with an extent to which a luminance of the display area is reduced. The comparator/selector may be adapted to calculate respective luminance set values corresponding to the first and second luminance control signals, and to provide the second luminance control signal to the scan driver when the luminance set value corresponding to the second luminance control signal is lower than the luminance set value corresponding to the first luminance control signal. The comparator/selector may be adapted to provide a first selection signal to the first luminance control unit, the first selection signal being for controlling the first luminance control unit to output a standard gamma signal. The comparator/selector may be adapted to provide the standard gamma signal outputted by the first luminance control unit to the data driver. The comparator/selector may be adapted to calculate luminance set values corresponding to the first and second luminance control signals, and to provide the first luminance control signal to the data driver when the luminance set value corresponding to the first luminance control signal is lower than the luminance set value corresponding to the second luminance control signal. The comparator/selector may be adapted to provide a second selection signal to the second luminance control unit, the second selection signal being for controlling the second luminance control unit to be turned off. The first luminance control unit may include an analog/digital converter for converting the optical sensor signal, which is an analog signal, to a digital sensor signal; a counter for counting pulses to generate a counting signal during one frame period; a converter processor for outputting a control signal corresponding to the digital sensor signal and the counting signal; a register generation unit for dividing the brightness of the ambient light into a plurality of brightness levels and storing a plurality of register set values corresponding to the brightness levels; a first selection unit for selecting one register set value corresponding to the control signal outputted by the converter processor, among the plurality of register set values stored in the register generation unit, and outputting the selected one register set value; and a gamma correction unit for generating the first luminance control signal, which is a gamma correction signal, corresponding to the selected one register set value supplied by the first selection unit. The first luminance control unit may further include a second selection unit for controlling ON/OFF of the first luminance control unit according to a first selection signal supplied by the comparator/selector. The second luminance control unit may include a data sum-up unit for summing up the data of one frame to generate sum-up data and generating control data having at least two bits including the most significant bits of the sum-up data; a lookup table for storing a width information of the light emission control signal corresponding to the control data; a controller for extracting the width information of the light emission control signal corresponding to the control data from the lookup table; and a second luminance control signal generation unit for generating the second luminance control signal corresponding to the width information

of the light emission control signal supplied by the controller. The width of the light emission control signal may be set so that a luminance of the display area is decreased with an increasing value of the control data. The second luminance control unit may further include a switch unit for selectively providing the data of one frame to the data sum-up unit in accordance with a second selection signal supplied by the comparator/selector.

Another aspect of an exemplary embodiment according to the present invention is a method for driving an organic light emitting display device having a display area to display an image, the method including: generating an optical sensor signal corresponding to a brightness of an ambient light; generating a first luminance control signal for controlling a gamma-corrected gray level voltage of a data signal in accordance with the optical sensor signal; generating a second luminance control signal for controlling a width of a light emission control signal in accordance with data of one frame of the image; and comparing the first luminance control signal with the second luminance control signal and controlling a luminance of the display area in accordance with the first luminance control signal or the second luminance control signal.

The method may further include controlling the luminance of the display area in accordance with the first luminance control signal or the second luminance control signal in accordance with an extent to which the luminance of the display area is reduced. The method may further include: calculating luminance set values corresponding to the first and second luminance control signals; and generating a corrected data signal corresponding to the first luminance control signal if the luminance set value corresponding to the first luminance control signal is lower than the luminance set value corresponding to the second luminance control signal. The method may further include: calculating luminance set values corresponding to the first and second luminance control signals; and generating a light emission control signal having a width corresponding to the second luminance control signal if the luminance set value corresponding to the second luminance control signal is lower than the luminance set value corresponding to the first luminance control signal.

BRIEF DESCRIPTION OF THE DRAWINGS

These and/or other aspects and features of the invention will become apparent and more readily appreciated from the following description of the exemplary embodiments, taken in conjunction with the accompanying drawings of which:

FIG. 1 is a block diagram showing a configuration of an organic light emitting display device according to one exemplary embodiment of the present invention.

FIG. 2 is a block diagram showing one exemplary embodiment of a first luminance control unit shown in FIG. 1.

FIG. 3 is a block diagram showing one exemplary embodiment of an A/D converter shown in FIG. 2.

FIG. 4 is a block diagram showing one exemplary embodiment of a gamma correction unit shown in FIG. 2.

FIG. 5A and FIG. 5B are graphs showing a gamma curve according to the gamma correction unit shown in FIG. 4.

FIG. 6 is a block diagram showing one exemplary embodiment of a second luminance control unit shown in FIG. 1.

FIG. 7 is an exemplary embodiment of a table illustrating values of a lookup table shown in FIG. 6.

DESCRIPTION OF MAJOR PARTS IN THE FIGURES

100: display area	200: scan driver
300: data driver	400: first luminance control unit
500: optical sensor	600: second luminance control unit
700: comparator/selector	

DETAILED DESCRIPTION OF EMBODIMENTS

Hereinafter, exemplary embodiments according to the present invention will be described with reference to the accompanying drawings. Here, when one element is described as being connected to another element, one element may be not only directly connected to another element but instead may be indirectly connected to another element via one or more other elements. Further, some of the elements that are not essential to the complete understanding of the invention have been omitted for clarity. Also, like reference numerals refer to like elements throughout.

Exemplary embodiments according to the present invention provide an organic light emitting display device capable of controlling luminance according to a brightness of the ambient light and data of one frame. The embodiments of the present invention may result in reduced power consumption.

If the brightness of the ambient light and the luminance corresponding to data of one frame are both employed to reduce or limit a luminance of a display area, then the luminance of the display area may be excessively reduced, resulting in deteriorated visibility. Therefore, in an exemplary embodiment according to the present invention, when the brightness level of the ambient light is below a reference level (e.g., a predetermined or preset brightness level), the data of one frame is not used to further reduce or limit the luminance of the display area.

FIG. 1 is a block diagram showing a configuration of an organic light emitting display device according to one exemplary embodiment of the present invention.

Referring to FIG. 1, the organic light emitting display device according to one exemplary embodiment of the present invention includes a display area 100, a scan driver 200, a data driver 300, a first luminance control unit 400, an optical sensor 500, a second luminance control unit 600 and a comparator/selector 700.

The display area 100 includes a plurality of pixels 110 connected to scan lines (S1 to Sn), light emission control lines (EM1 to EMn) and data lines (D1 to Dm). Here, one pixel 110 has at least one organic light emitting diode and may be composed of at least two subpixels which emit the light having different colors, each subpixel having one organic light emitting diode having a corresponding color.

The display area 100 displays an image in accordance with a first power source (ELVdd) and a second power source (ELVss) supplied from the outside, a scan signal and a light emission control signal supplied from the scan driver 200, and a data signal supplied from the data driver 300.

The scan driver 200 is electrically connected with the display area 100 through the scan lines (S1 to Sn) and the light emission control lines (EM1 to EMn). The scan driver 200 generates the scan signal and the light emission control sig-

nal. The scan signal generated in the scan driver **200** is sequentially supplied to each of the scan lines (S1 to Sn), and the light emission control signal is sequentially supplied to each of the light emission control lines (EM1 to EMn).

Here, a pulse width (or width) of the light emission control signal generated in the scan driver **200** is controlled by using a second luminance control signal (Vc2) when the second luminance control signal (Vc2) is supplied from the comparator/selector **700**. A light emission time of the pixels **110** is varied according to the changes in the pulse width of the light emission control signal as described above, resulting in adjustment of the entire brightness of the display area **100**.

The data driver **300** is electrically connected with the display area **100** through the data lines (D1 to Dm). The data driver **300** generates a data signal corresponding to image data (RGB Data) inputted therein during one frame period, and a gamma correction signal (a first luminance control signal (Vc1)) or a standard gamma signal (Vn) supplied from the comparator/selector **700**. The data signal generated in the data driver **300** is supplied to the data lines (D1 to Dm), and then supplied to each of the pixels **110** in synchronization with the scan signal.

Here, a gray level voltage of the data signal generated in the data driver **300** is controlled by the first luminance control signal (Vc1) corresponding to a brightness of the ambient light if the first luminance control signal (Vc1) is supplied from the comparator/selector **700**. Therefore, an electric current having a magnitude greater than a reference value (e.g., a previously set predetermined value) is prevented from flowing to the display area **100**, resulting in adjustment of the entire brightness of the display area **100**.

The first luminance control unit **400** generates a first luminance control signal (Vc1) for controlling a gamma-corrected gray level voltage of the data signal in accordance with an optical sensor signal (Ssens) supplied from the optical sensor **500**, and provides the generated first luminance control signal (Vc1) to the comparator/selector **700**.

More particularly, the first luminance control unit **400** selects a gamma value according to control signals supplied from the outside, such as the vertical synchronizing signal (Vsync) and the clock signal (CLK), and the optical sensor signal (Ssens) supplied from the optical sensor **500**, and outputs the first luminance control signal (Vc1) which is a gamma correction signal corresponding to the selected gamma value.

The first luminance control unit **400** is set to an ON or OFF state according to a first selection signal (Vs1) supplied from the comparator/selector **700**. For example, the first luminance control unit **400** may output the first luminance control signal (Vc1) corresponding to the optical sensor signal (Ssens) if the first selection signal (Vs1) for directing "ON" is inputted into the first luminance control unit **400**, and output the previously set standard gamma signal (Vn) if the first selection signal (Vs1) for directing "OFF" is inputted.

The optical sensor **500** has an optical sensor element such as a phototransistor or photodiode to sense a brightness of an external light, namely, the ambient light, and generates the optical sensor signal (Ssens) corresponding to the brightness of the ambient light. The optical sensor signal (Ssens) generated in the optical sensor **500** is supplied to the first luminance control unit **400**.

The second luminance control unit **600** generates a second luminance control signal (Vc2) for controlling a pulse width of the light emission control signal in accordance with data (RGB Data) of one frame, and provides the generated second luminance control signal (Vc2) to the comparator/selector **700**.

In one exemplary embodiment, the second luminance control unit **600** generates the second luminance control signal (Vc2) corresponding to a sum-up value of the data (RGB Data) supplied therein during one frame period, and the synchronizing signal (Vsync) and clock signal (CLK).

The second luminance control unit **600** is controlled so that it can be turned on or off according to a second selection signal (Vs2) supplied from the comparator/selector **700**. For example, the second luminance control unit **600** outputs the second luminance control signal (Vc2) corresponding to a sum-up value of the data of one frame if the second selection signal (Vs2) for directing "ON" is inputted into the second luminance control unit **600**, and does not operate if the second selection signal (Vs2) for directing "OFF" is inputted. However, the second luminance control unit **600** may be set to be turned on again if new data is introduced into a memory even after the second luminance control unit **600** is turned off by the second selection signal (Vs2), and therefore a luminance value corresponding to the data is controlled so that it can be suitably reflected.

In one embodiment, the comparator/selector **700** compares the first luminance control signal (Vc1) supplied from the first luminance control unit **400** with the second luminance control signal (Vc2) supplied from the second luminance control unit **600**, and outputs as a luminance control signal, one of the first luminance control signal (Vc1) and the second luminance control signal (Vc2), whichever one that controls the luminance of the display area **100** to be comparatively lower, to the data driver **300** or the scan driver **200**.

For this purpose, the comparator/selector **700** calculates luminance set values corresponding to each of the first and second luminance control signals (Vc1, Vc2) to compare the two values with each other. And, the comparator/selector **700** outputs a luminance control signal that corresponds to a comparatively lower luminance set value.

For example, the comparator/selector **700** selects the second luminance control signal (Vc2) and supplies the selected second luminance control signal (Vc2) to the scan driver **200** if the luminance set value of the second luminance control signal (Vc2) is lower than the luminance set value of the first luminance control signal (Vc1). In this case, the comparator/selector **700** generates the first selection signal (Vs1) for directing "OFF" of the first luminance control unit **400**. In one exemplary embodiment, the first selection signal (Vs1) controls the first luminance control unit **400** to output the standard gamma signal (Vn) previously set regardless of the optical sensor signal (Ssens), and supplies the generated first selection signal (Vs1) to the first luminance control unit **400**. In this case, the first luminance control unit **400** provides the standard gamma signal (Vn) to the comparator/selector **700**, and the comparator/selector **700** in turn supplies the standard gamma signal (Vn) to the data driver **300**.

In other words, if the second luminance control signal (Vc2) has a lower luminance set value than that of the first luminance control signal (Vc1), then the luminance of the display area **100** is controlled by using the light emission control signal having a pulse width corresponding to the second luminance control signal (Vc2) supplied from the scan driver **200**, and the gamma-corrected gray level voltage of the data signal is substantially constantly sustained at each gray level by using the standard gamma signal (Vn).

If the first luminance control signal (Vc1) has a lower luminance set value than that of the second luminance control signal (Vc2), then the comparator/selector **700** selects the first luminance control signal (Vc1) and supplies the selected first luminance control signal (Vc1) to the data driver **300**. In this case, the comparator/selector **700** generates the second selec-

tion signal (Vs2) for controlling the second luminance control unit 600 to be turned off, and supplies the generated second selection signal (Vs2) to the second luminance control unit 600.

In other words, if the first luminance control signal (Vc1) has a lower luminance set value than that of the second luminance control signal (Vc2), then the gamma-corrected gray level voltage of the data signal is controlled to correspond to the first luminance control signal (Vc1), and therefore the luminance of the display area 100 is controlled.

In one exemplary embodiment, the organic light emitting display device, in order to control the brightness of the display area 100 in accordance with the brightness of the ambient light and the data of one frame in a more effective manner, when new data is introduced into the memory, the first and second luminance control units 400, 600 may be reset to output both of the first and second luminance control signals, and therefore the comparator/selector 700 may selectively output any of the luminance control signals to correspond to a circumstance.

As described above, the organic light emitting display device in one exemplary embodiment controls the luminance of the display area 100 in accordance with the brightness of the ambient light and the data of one frame. Here, the organic light emitting display device selects one of the first and second luminance control signals, whichever one that reduces the luminance of the display area 100 to a larger extent. By suitably selecting one of the brightness of the ambient light or the data of one frame to limit the luminance of the display area 100, rather than using both the brightness of the ambient light and the data of one frame, an excessive reduction in the luminance is prevented.

Also, if one of the first and second luminance control units 400, 600 is turned off, for example, if the second luminance control unit 600 is turned off by the second selection signal (Vs2) supplied from the comparator/selector 700, then unnecessary power consumption caused by concurrent operation of both the first and second luminance control units 400, 600 may be prevented.

Also, if the pulse width of the light emission control signal is limited by the second luminance control signal (Vc2) generated in the second luminance control unit 600, then excessive electric current is prevented from flowing to the display area 100, resulting in reduction in the power consumption.

FIG. 2 is a block diagram showing one embodiment of the first luminance control unit 400 shown in FIG. 1.

Referring to FIG. 2, the first luminance control unit 400 in one embodiment includes an analog/digital converter 412, a counter 413, a converter processor 414, a register generation unit 415, a first selector 416, a second selector 417 and a gamma correction unit 418.

The analog/digital converter (hereinafter, referred to as an A/D converter) 412 compares an analog optical sensor signal (Ssens) outputted from the optical sensor 500 to a reference voltage (e.g., a predetermined reference voltage), and outputs a digital sensor signal (SD) corresponding to the reference voltage.

For example, in one embodiment, when the A/D converter 412 divides a surrounding brightness into four levels and outputs a 2-bit digital sensor signal (SD) according to the surrounding brightness, the A/D converter 412 may output a digital sensor signal (SD) of "11" in the brightest surrounding brightness level, and output a digital sensor signal (SD) of "10" in a relatively bright surrounding brightness level. Also, the A/D converter 412 may output a digital sensor signal (SD)

of "01" in a relatively dark surrounding brightness level, and output a digital sensor signal (SD) of "00" in the darkest surrounding brightness level.

The counter 413 counts a number (e.g., predetermined number) of pulses (e.g., clock cycles of a clock signal (CLK)) during a certain time, for example during one frame period, by using a vertical synchronizing signal (Vsync) supplied from the outside, and outputs a counting signal (Cs) corresponding to the number (e.g., a predetermined number) of pulses.

For example, in the case of the counter 413 using the binary value having 2 bits, the counter 413 is reset to a value of '00' when the vertical synchronizing signal (Vsync) is inputted, and then the number to '11' may be counted by sequentially shifting the clock signal (CLK). In one embodiment, as those skilled in the art would appreciate, the clock signal (CLK) has a period (i.e., clock cycle) equal to 1/4 of one frame of an image (e.g., a video image), such that the clock signal (CLK) is used by the counter 413 to count from '00' to '11' during one frame, and then the counter 413 is reset to a reset state when the vertical synchronizing signal (Vsync) is inputted to the counter 413 again after one frame.

As in the above operation, the counter 413 sequentially counts the number from '00' to '11' and outputs a counting signal (Cs) corresponding to the counted number into the converter processor 414. This way, the counting signal (Cs) changes through '00', '01', '10' and '11' during one frame and back to '00' at the end of the frame in synchronization with the Vsync signal.

The converter processor 414 uses the digital sensor signal (SD) inputted from the A/D converter 412 and the counting signal (Cs) inputted from the counter 413 to output a control signal which will select a set value of each of the registers.

In other words, the converter processor 414 outputs a control signal corresponding to the digital sensor signal (SD) selected when the counting signal (Cs) outputted by the counter 413 is identical to the digital sensor signal (SD), and sustains the control signal until the next time when the digital sensor signal (SD) matches the counting signal (Cs). This way, the outputted control signal can be changed in the next frame when the digital sensor signal (SD) inputted from the A/D converter 412 is identical to the counting signal (Cs) inputted from the counter 413.

For example, if the ambient light is in the brightest state, then the converter processor 414 outputs a control signal (for example, a control signal set to 2-bit value such as '11') corresponding to the digital sensor signal (SD) of '11', and sustains the control signal until the digital sensor signal (SD) again matches the counting signal (Cs) outputted by the counter 413 according to the clock cycles (or pulses) of the clock signal (CLK). If the ambient light is in the darkest state, then the converter processor 414 outputs a control signal corresponding to the digital sensor signal (SD) of '00', and sustains the control signal until the digital sensor signal (SD) again matches the counting signal (Cs) outputted by the counter 413 according to the clock cycles (or pulses) of the clock signal (CLK). When the ambient light is in a relatively bright or dark state, the converter processor 414 outputs a control signal corresponding to the digital sensor signal (SD) of '10' or '01' and sustains the control signal until the next time when the digital sensor signal (SD) matches the counting signal (Cs) in the same manner as described above. In other embodiments, the control signal may be sustained during one or more frames or a partial frame using other methods as those skilled in the art would appreciate.

The register generation unit **415** divides a brightness of the ambient light into a plurality of brightness levels and stores a plurality of register set values corresponding to the brightness levels.

The first selection unit **416** selects register set values corresponding to the control signals, set by the converter processor **414**, among the a plurality of the register set values stored in the register generation unit **415**, and then outputs the selected register set values.

The second selection unit **417** controls ON/OFF of the first luminance control unit **400** in accordance with the first selection signal (Vs1) supplied from the comparator/selector **700**. For example, the second selection unit **417** receives the first selection signal (Vs1) set to a 1-bit value. If a value of '1' is selected, the second selection unit **417** operates (is turned on) to supply a register set value corresponding to the optical sensor signal (Ssens), supplied from the first selection unit **416**, to the gamma correction unit **418**. If a value of '0' is selected, the second selection unit **417** is turned off to output the standard gamma signal (Vn). This way, the brightness is selectively controlled according to the ambient light. Hereinafter, the first luminance control unit **400** of FIG. 2 will be described in reference to a case where the first luminance control unit **400** is turned on (or operates).

The gamma correction unit **418** generates a first luminance control signal (Vc1) which is a gamma correction signal corresponding to the register set values supplied from the second selection unit **417**. Here, the first luminance control signal (Vc1) has different values according to the brightness of the ambient light since the register set values supplied to the gamma correction unit **418** corresponds to the optical sensor signal (Ssens) inputted from the optical sensor **500**. Such an operation is carried out for each of subpixels, for example, red (R), green (G) and blue (B) subpixels, respectively.

FIG. 3 is a diagram showing one exemplary embodiment of the A/D converter **412** shown in FIG. 2.

Referring to FIG. 3, the A/D converter **412** includes first, second and third selectors **21**, **22**, **23**, first, second and third comparators **24**, **25**, **26** and an adder **27**.

The first to third selectors **21**, **22**, **23** receive a plurality of gray level voltages distributed through a plurality of resistance arrays for generating a plurality of gray level voltages (VHI to VHO), and output the gray level voltages corresponding to differently set 2-bit values, which are referred to as reference voltages (VH, VM and VL).

The first comparator **24** compares the analog optical sensor signal (Ssens) with a first reference voltage (VH) and outputs the resultant value. For example, the first comparator **24** may output "1" if an analog optical sensor signal (Ssens) is higher than the first reference voltage (VH), and "0" if an analog optical sensor signal (Ssens) is lower than the first reference voltage (VH).

In the same manner, the second comparator **25** outputs a value obtained by comparing the analog optical sensor signal (Ssens) with a second reference voltage (VM), and the third comparator **26** outputs a value obtained by comparing the analog optical sensor signal (Ssens) with a third reference voltage (VL).

Also, a range of the analog optical sensor signal (Ssens) corresponding to the same digital sensor signal (SD) may be changed by varying the first to third reference voltages (VH to VL).

The adder **27** adds up all of the resultant values outputted from the first to third comparator **24**, **25**, **26** and outputs the values as a 2-bit digital sensor signal (SD).

Hereinafter, an operation of the A/D converter **412** shown in FIG. 3 will be described in detail, assuming that the first reference voltage (VH) is set to 3V, the second reference voltage (VM) is set to 2V, the third reference voltage (VL) is set to 1V, and a voltage value of the analog optical sensor signal (Ssens) is increased as the ambient light becomes brighter.

If the analog optical sensor signal (Ssens) has a lower voltage than 1 V, then all of the first to third comparators **24**, **25**, **26** output '0', and therefore the adder **27** outputs a digital sensor signal (SD) of '00'.

Also, if the analog optical sensor signal (Ssens) has a voltage between 1V and 2V, then the first to third comparators **24**, **25**, **26** output '0', '0', '1' respectively, and therefore the adder **27** outputs a digital sensor signal (SD) of '01'.

In the same manner, if the analog optical sensor signal (Ssens) has a voltage between 2V and 3V, then the adder **27** outputs a digital sensor signal (SD) of '10', and if the analog optical sensor signal (Ssens) has a higher voltage than 3V or more, then the adder **27** outputs a digital sensor signal (SD) of '11'.

The A/D converter **412** divides a brightness of the ambient light into four brightness levels while being driven in the above-mentioned manner, and then outputs '00' in the darkest brightness level, outputs '01' in a relatively dark brightness level, outputs '10' in a relatively bright brightness level, and outputs '11' in the brightest brightness level.

FIG. 4 is a diagram showing one example of a gamma correction unit shown in FIG. 2.

Referring to FIG. 4, the gamma correction unit **418** includes a ladder resistor **61**, an amplitude control register **62**, a curve control register **63**, a maximum voltage selector **64**, a minimum voltage selector **65**, first, second, third and fourth intermediate voltage selectors **66**, **67**, **68** and **69**, and a gray level voltage amplifier **70**.

The ladder resistor **61** sets the highest level voltage (VHI) supplied from the outside, as a reference voltage, and includes a plurality of variable resistors connected in series between the lowest level voltage (VLO) and the reference voltage (VHI). In this case, a plurality of gray level voltages are generated through the ladder resistor **61**.

On one hand, if the ladder resistor **61** is set to a low value, amplitude modulation range becomes narrow but its modulation accuracy is improved. On the other hand, if the ladder resistor **61** is set to a high value, amplitude modulation range becomes wide but its modulation accuracy is deteriorated.

The amplitude control register **62** supplies size data to the maximum voltage selector **64** and the minimum voltage selector **65**, respectively. The size data determines the sizes of the highest gray level voltage and the lowest gray level voltage.

For example, the amplitude control register **62** may receive an upper 10-bit value among the register set values, and then output the uppermost (or most significant) 3-bit register set values into the maximum voltage selector **64** and output 7-bit register set values to the minimum voltage selector **65**. At this time, the number of gray levels to be selected may be increased by increasing the set bit number and a gray level voltage may be differently selected by varying the register set values.

The maximum voltage selector **64** selects a gray level voltage corresponding to the 3-bit register set values, supplied from the amplitude control register, among a plurality of the gray level voltages distributed through the ladder resistor **61**, and then outputs the selected gray level voltage as the highest voltage (V0) for displaying the lowest gray levels.

The minimum voltage selector **65** selects a gray level voltage corresponding to the 7-bit register set values, supplied from the amplitude control register, among a plurality of the gray level voltages distributed through the ladder resistor **61**, and then outputs the selected gray level voltage as the lowest voltage (**V63**) for displaying the highest gray levels.

The curve control register **63** outputs gamma data into a plurality of intermediate voltage selectors **66**, **67**, **68** and **69**, respectively, the gamma data being capable of improving or optimizing display characteristics of the display area **100**.

For example, the curve control register **63** may receive a lower 16-bit value among the register set values, and output a 4-bit register set value into the first to fourth intermediate voltage selectors **66** to **69**, respectively. At this time, the register set value may be varied, and the gray level voltage, which may be selected according to the register set value, may be also adjusted.

Here, the upper 10-bit values among the register values generated in the register generation unit **415** are inputted into the amplitude control register **62**, and the lower 16-bit values are inputted into the curve control register **63**, and then the upper 10-bit values and the lower 16-bit values are selected as the register set values.

The first to fourth intermediate voltage selectors **66** to **69** select intermediate voltages corresponding to inflection points whose inclination is changed in a gamma curve showing a relation of the gamma-corrected gray level voltages corresponding to gray levels so as to correspond to the register set values supplied from the curve control register **63**. Accordingly, the number of the intermediate voltage selectors **66** to **69** is set to be the same as the number of the inflection points in the gamma curve showing the optimum display characteristics of the display area **100**.

More particularly, the first intermediate voltage selector **66** distributes a voltage between the gray level voltage outputted from the maximum voltage selector **64** and the gray level voltage outputted from the minimum voltage selector **65** using a plurality of resistance arrays, and then select and outputs the gray level voltages corresponding to the 4-bit register set values.

The second intermediate voltage selector **67** distributes a voltage between the gray level voltage outputted from the maximum voltage selector **64** and the gray level voltage outputted from the first intermediate voltage selector **66** using a plurality of resistance arrays, and then selects and outputs the gray level voltages corresponding to the 4-bit register set values.

The third intermediate voltage selector **68** distributes a voltage between the gray level voltage outputted from the maximum voltage selector **64** and the gray level voltage outputted from the second intermediate voltage selector **67** using a plurality of resistance arrays, and then selects and outputs the gray level voltages corresponding to the 4-bit register set values.

The fourth intermediate voltage selector **69** distributes a voltage between the gray level voltage outputted from the maximum voltage selector **64** and the gray level voltage outputted from the third intermediate voltage selector **68** using a plurality of resistance arrays, and then selects and outputs the gray level voltages corresponding to the 4-bit register set values.

In the operation as described above, it is possible to adjust a curve of the intermediate gray level unit according to the register set values of the curve control register **63**, and therefore a gamma characteristic may be easily adjusted, depending on the characteristic of each of light emitting elements. Also, in order to bulge the gamma curve characteristic down-

wards, a resistor value of the ladder resistor **61** is set so that an electric potential difference between the gray levels can be increased as a low gray level is displayed, while a resistor value of the ladder resistor **61** is set so that an electric potential difference between the gray levels can be decreased as a low gray level is displayed so as to bulge the gamma curve characteristic upwards.

The gray level voltage amplifier **70** outputs a plurality of gray level voltages corresponding to a plurality of gray levels displayed in the display area **100**, respectively. For the sake of convenience, an output of the gray level voltage corresponding to 64 gray levels is shown in FIG. **4**. However, the present invention is not limited thereto.

More particularly, the gray level voltage amplifier **70** receives intermediate voltages from the plurality of the intermediate voltage selectors **66** to **69**, generates a plurality of voltage levels as the gray level voltages and outputs each of the gray level voltages, wherein a plurality of the voltage levels have a linear relation within two intermediate voltage ranges and the gray level voltages may display all of the gray levels. In one embodiment, the gray level voltage amplifier **70** is composed of a plurality of resistors having the same resistance and connected in series. However, the present invention is not limited thereto.

The above operation is carried out so that red (R), green (G), blue (B) subpixels can obtain substantially the same luminance characteristic, considering the changes in their own characteristics of red (R), green (G), blue (B) light-emitting elements. For this purpose, the amplitude and the curve may be differently set in the red (R), green (G), blue (B) subpixels through the amplitude control register **62** and the curve control register **63** by installing the gamma correction unit **418** in every red (R), green (G), blue (B) subpixel groups.

FIG. **5A** and FIG. **5B** are graphs showing a gamma curve according to the gamma correction circuit **418** shown in FIG. **4**.

FIG. **5A** shows that the highest voltage for displaying the lowest gray level is not changed, and amplitude of the lowest voltage for displaying the highest gray level may be adjusted according to the 7-bit register set value outputted by the amplitude control register **62**. Here, an OFF voltage ( $V_{off}$ ) is a voltage corresponding to a black gray level (a gray level value of 0), and an ON voltage ( $V_{on}$ ) is a voltage corresponding to a white gray level (a gray level value of 63).

A reference numeral **A1** represents a gamma curve corresponding to the digital sensor signal (SD) when the surrounding brightness is in the darkest state, and a reference numeral **A2** represents a gamma curve corresponding to the digital sensor signal (SD) when the surrounding brightness is in a relatively dark state. Also, a reference numeral **A3** represents a gamma curve corresponding to the digital sensor signal (SD) when the surrounding brightness is in a relatively bright state, and a reference numeral **A4** represents a gamma curve corresponding to the digital sensor signal (SD) when the surrounding brightness is in the brightest state. In the gamma curves **A1**, **A2**, **A3** and **A4**, an off voltage  $V_{off}$  corresponds to a black gray scale level (i.e., gray level value of 0) and on voltages  $V_{on1}$ ,  $V_{on2}$ ,  $V_{on3}$  and  $V_{on4}$ , respectively, correspond to a white gray scale level (i.e., gray level value of 63).

In one embodiment, in order to reduce the amplitude range of the gray level voltage, the minimum voltage selector **65** is set to select the highest voltage level by adjusting a register set value of the amplitude control register **62**. Also, in order to increase the amplitude range of the gray level voltage, the minimum voltage selector **65** is set to select the lowest voltage level.

FIG. 5B shows that a gamma curve is adjusted by changing an intermediate level of the gray level voltage according to the register set values supplied by the register curve control register 63, without changing the highest voltage for displaying the lowest gray level or the lowest voltage for displaying the highest gray level.

The 4-bit register set values are respectively inputted into the first to fourth intermediate voltage selectors 66 to 69, and four gamma values corresponding to the register set values are selected to generate a gamma curve. As can be seen in FIG. 5B, the change in inclination of a C2 curve is higher than the change in inclination of a C1 curve and lower than the change in inclination of a C3 curve.

As shown in FIG. 5A and FIG. 5B, the gray level voltages are changed to form a gamma curve by changing a set value of the gamma control register. Accordingly, it has been illustrated that brightness of each of the pixels 110 in the display area 100 may be adjusted.

FIG. 6 is a block diagram showing one exemplary embodiment of the second luminance control unit 600 shown in FIG. 1.

Referring to FIG. 6, the second luminance control unit 600 includes a switch unit 610, a data sum-up unit 620, a controller 630, a lookup table 635 and a second luminance control signal (Vc2) generation unit 640.

The switch unit 610 controls whether or not control signals such as a synchronizing signal (Vsync) and a clock signal (CLK), and data (RGB Data) of one frame are supplied to the data sum-up unit 620 in accordance with the second selection signal (Vs2) supplied by the comparator/selector 700. In one embodiment, the clock signal (CLK) inputted into the second luminance control unit 600 is identical to the clock signal (CLK) inputted into the first luminance control unit 400. In other embodiments, the clock signals (CLK) may be similar or different.

For example, the switch unit 610 supplies the control signals such as the synchronizing signal (Vsync) and the clock signal (CLK), and the data (RGB Data) of one frame to the data sum-up unit 620 when the second selection signal (Vs2) directing ON of the second luminance control unit 600 is inputted. Further, the switch unit 610 interrupts the supply of the control signals such as the synchronizing signal (Vsync) and the clock signal (CLK), and the data (RGB Data) of one frame to the data sum-up unit 620 in the other case, that is, when the second selection signal (Vs2) directing OFF of the second luminance control unit 600 is inputted.

The data sum-up unit 620 generates sum-up data obtained by adding up image data (RGB Data) inputted during one frame period, and generates control data having at least two bits including the uppermost bits (i.e., the most significant bits) of the sum-up data. Hereinafter, it will be assumed that an upper (i.e., most significant) 5-bit value of the sum-up data is set to the control data for the sake of convenience. Here, a high value of the sum-up data means that the data sum-up unit 620 includes a large amount of data having a high luminance more than a reference luminance (e.g., a predetermined luminance), and a low value of the sum-up data means that the data sum-up unit 620 includes a small amount of data having a high luminance more than the reference luminance (e.g., the predetermined luminance). The control data generated in the data sum-up unit 620 is transmitted to the second controller 630.

The lookup table 635 stores a width (EW) information of the light emission control signal corresponding to the control data (for example, control data from 0 to 31 if the control data is set to a 5-bit value). Here, the width (EW) of the light emission control signal is a data value having information on

the width of the light emission control signal for controlling a light emission time of the pixels 110, and the width (EW) of the light emission control signal stored in the lookup table 635 is set so that the luminance of the display area 100 can be reduced with an increasing value of the control data. That is to say, the width (EW) of the light emission control signal is set to limit an amount of electric current flowing to the display area 100 by reducing a light emission time of the pixels 110 as the value of the control data increases.

The controller 630 extracts from the lookup table 635 the width (EW) information of the light emission control signal that corresponds to the control data supplied from the data sum-up unit 620, and transmits the extracted width (EW) information to the second luminance control signal (Vc2) generation unit 640.

The second luminance control signal (Vc2) generation unit 640 generates a second luminance control signal (Vc2) corresponding to the width (EW) information of the light emission control signal supplied from the controller 630, and outputs the generated second luminance control signal (Vc2) to the comparator/selector 700.

FIG. 7 is a block diagram showing one exemplary embodiment of the lookup table 635 shown in FIG. 6. The lookup table 635 shown in FIG. 7 is based on an assumption that the amount of time that an electric current flows to the pixel 110 increases as the width (EW) of the light emission control signal increases, but the description provided herein is not intended to limit the scope of the invention. In practice, the content stored in the lookup table 635 may be varied depending on the configuration of the pixel circuits, the resolution and size of the display area 100, etc., as those skilled in the art would appreciate.

Referring to FIG. 7, the width (EW) of the light emission control signal corresponding to an upper 5-bit value (namely, the control data) of the sum-up data is stored in the lookup table 635. Here, the width (EW) of the light emission control signal is set so that it can be narrowed with an increasing value of the control data so as to limit a power consumption within a constant range (in other words, to limit luminance). Here, if the control data has at least one value including the minimum value, then the width (EW) of the light emission control signal is sustained at a constant width.

By way of example, if the control data is set to a value of '4' or less, the width (EW) of the light emission control signal is set to a width corresponding to 325 cycles of a horizontal synchronizing signal (Hsync) so as not to limit the luminance. As described above, when the control data has at least one value including the minimum value, if the width (EW) of the light emission control signal is not limited, a contrast ratio may be improved when a dark image is displayed, and therefore an image having an improved contrast may be displayed.

If the control data is set to a value of '5' or more, then the width (EW) of the light emission control signal is slowly narrowed with an increasing value of the control data. As described above, if the control data has a higher value than at least one value including the minimum value, then the power consumption may be sustained within a constant range since the luminance is lowered as the width (EW) of the light emission control signal gets narrow. Also, eye fatigue may be alleviated due to the limited luminance of the display area 100 even if one watches images for a long time. Actually, a ratio for limiting the luminance is increased since the increased number of pixels displaying high gray levels increases the value of the control data.

In order to prevent the excessive reduction of the luminance, a maximum limitation ratio for the luminance is defined, and therefore the pixels 110 displaying high gray

levels are set to have a light emitting ratio of 34% or less even if these pixels 110 having high gray levels take a majority of an area of the display area 100. In other words, if the control data has a higher value than at least one value including the minimum value, then the width (EW) of the light emission control signal should not be set to a width less than a reference width (e.g., a predetermined width). In one embodiment, the lookup table 635 is applied to a moving image. In one embodiment, if an image displayed in the organic light emitting display device includes a still image and a moving image, the limited range of the luminance is varied according to kinds of the image. For example, in one embodiment, the maximum limitation ratio of the luminance may reach 50% in the case of the still image.

As described above, the organic light emitting display device in exemplary embodiments according to the present invention may be useful in preventing an excessive reduction in the luminance by controlling the luminance of the display area in accordance with the brightness of the ambient light and the data of one frame. Here, optimum driving conditions are employed, in which one of the first and second luminance control signals that limits the luminance of the display area to a larger extent, is selected. Also, unnecessary power consumption caused by concurrent operations of the first and second luminance control units may be prevented by turning off one of the first and second luminance control units. Further, if the pulse width of the light emission control signal is limited by the second luminance control signal generated in the second luminance control unit, then excessive electric current is prevented from flowing to the display area, resulting in reduction to the power consumption.

The description provided herein is just exemplary embodiments for the purpose of illustrations only, and not intended to limit the scope of the invention, so it should be understood that other equivalents and modifications could be made thereto without departing from the spirit and scope of the invention as those skilled in the art would appreciate. Therefore, it should be understood that the present invention has a scope of that is defined in the claims and their equivalents.

What is claimed is:

1. An organic light emitting display device for displaying an image, the organic light emitting display device having a plurality of scan lines, a plurality of light emission control lines and a plurality of data lines, and comprising:  
 a display area including a plurality of pixels coupled to the scan lines, the light emission control lines and the data lines;  
 a scan driver electrically coupled to the display area through the scan lines and the light emission control lines;  
 a data driver electrically coupled to the display area through the data lines;  
 an optical sensor for generating an optical sensor signal corresponding to a brightness of an ambient light;  
 a first luminance control unit for outputting a first luminance control signal for controlling a gamma-corrected gray level voltage of a data signal of the image, applied to the data lines, in accordance with the optical sensor signal;  
 a second luminance control unit for outputting a second luminance control signal for controlling a width of a light emission control signal applied to the light emission control lines, in accordance with data of one frame of the image; and  
 a comparator/selector for comparing the first luminance control signal with the second luminance control signal

to provide the first luminance control signal or the second luminance control signal to the data driver or the scan driver.

2. The organic light emitting display device according to claim 1, wherein the comparator/selector is adapted to output the first luminance control signal or the second luminance control signal in accordance with an extent to which a luminance of the display area is reduced.

3. The organic light emitting display device according to claim 1, wherein the comparator/selector is adapted to calculate respective luminance set values corresponding to the first and second luminance control signals, and to provide the second luminance control signal to the scan driver when the luminance set value corresponding to the second luminance control signal is lower than the luminance set value corresponding to the first luminance control signal.

4. The organic light emitting display device according to claim 3, wherein the comparator/selector is adapted to provide a selection signal to the first luminance control unit, the selection signal being for controlling the first luminance control unit to output a standard gamma signal.

5. The organic light emitting display device according to claim 4, wherein the comparator/selector is adapted to provide the standard gamma signal outputted by the first luminance control unit to the data driver.

6. The organic light emitting display device according to claim 1, wherein the comparator/selector is adapted to calculate respective luminance set values corresponding to the first and second luminance control signals, and to provide the first luminance control signal to the data driver when the luminance set value corresponding to the first luminance control signal is lower than the luminance set value corresponding to the second luminance control signal.

7. The organic light emitting display device according to claim 6, wherein the comparator/selector is adapted to provide a selection signal to the second luminance control unit, the selection signal being for controlling the second luminance control unit to be turned off.

8. The organic light emitting display device according to claim 1, wherein the first luminance control unit comprises:  
 an analog/digital converter for converting the optical sensor signal, which is an analog signal, to a digital sensor signal;  
 a counter for counting pulses to generate a counting signal during one frame period;  
 a converter processor for outputting a control signal corresponding to the digital sensor signal and the counting signal;  
 a register generation unit for dividing the brightness of the ambient light into a plurality of brightness levels and storing a plurality of register set values corresponding to the brightness levels;  
 a selection unit for selecting one register set value corresponding to the control signal outputted by the converter processor, among the plurality of register set values stored in the register generation unit, and outputting the selected one register set value; and  
 a gamma correction unit for generating the first luminance control signal, which is a gamma correction signal, corresponding to the selected one register set value supplied by the selection unit.

9. The organic light emitting display device according to claim 8, wherein the first luminance control unit further comprises a second selection unit for controlling ON/OFF of the first luminance control unit according to a selection signal supplied by the comparator/selector.

10. The organic light emitting display device according to claim 1, wherein the second luminance control unit comprises:

- a data sum-up unit for summing up the data of one frame to generate sum-up data and generating control data having at least two bits including most significant bits of the sum-up data;
- a lookup table for storing a width information of the light emission control signal corresponding to the control data;
- a controller for extracting the width information of the light emission control signal corresponding to the control data from the lookup table; and
- a second luminance control signal generation unit for generating the second luminance control signal corresponding to the width information of the light emission control signal supplied by the controller.

11. The organic light emitting display device according to claim 10, wherein the width of the light emission control signal is set so that a luminance of the display area is decreased with an increasing value of the control data.

12. The organic light emitting display device according to claim 10, wherein the second luminance control unit further comprises a switch unit for selectively providing the data of one frame to the data sum-up unit in accordance with a selection signal supplied by the comparator/selector.

13. A method for driving an organic light emitting display device having a display area including a plurality of pixels coupled to a plurality of data lines, a plurality of scan lines and a plurality of light emission control lines, to display an image, the method comprising:

- generating an optical sensor signal corresponding to a brightness of an ambient light;
- generating a first luminance control signal for controlling a gamma-corrected gray level voltage of a data signal of the image, applied to the data lines, in accordance with the optical sensor signal;
- generating a second luminance control signal for controlling a width of a light emission control signal applied to the light emission control lines, in accordance with data of one frame of the image; and
- comparing the first luminance control signal with the second luminance control signal and controlling a luminance of the display area in accordance with the first luminance control signal or the second luminance control signal.

14. The method for driving an organic light emitting display device according to claim 13, further comprising controlling the luminance of the display area in accordance with the first luminance control signal or the second luminance control signal in accordance with an extent to which a luminance of the display area is reduced.

15. A method for driving an organic light emitting display device having a display area including a plurality of pixels coupled to a plurality of data lines, a plurality of scan lines and a plurality of light emission control lines, to display an image, the method comprising:

- generating an optical sensor signal corresponding to a brightness of an ambient light;
- generating a first luminance control signal for controlling a gamma-corrected gray level voltage of a data signal of the image, applied to the data lines, in accordance with the optical sensor signal;
- generating a second luminance control signal for controlling a width of a light emission control signal applied to the light emission control lines, in accordance with data of one frame of the image;

comparing the first luminance control signal with the second luminance control signal and controlling a luminance of the display area in accordance with the first luminance control signal or the second luminance control signal;

calculating luminance set values corresponding to the first and second luminance control signals; and

generating a corrected data signal corresponding to the first luminance control signal if the luminance set value corresponding to the first luminance control signal is lower than the luminance set value corresponding to the second luminance control signal.

16. A method for driving an organic light emitting display device having a display area including a plurality of pixels coupled to a plurality of data lines, a plurality of scan lines and a plurality of light emission control lines, to display an image, the method comprising:

generating an optical sensor signal corresponding to a brightness of an ambient light;

generating a first luminance control signal for controlling a gamma-corrected gray level voltage of a data signal of the image, applied to the data lines, in accordance with the optical sensor signal;

generating a second luminance control signal for controlling a width of a light emission control signal applied to the light emission control lines, in accordance with data of one frame of the image;

comparing the first luminance control signal with the second luminance control signal and controlling a luminance of the display area in accordance with the first luminance control signal or the second luminance control signal; and

calculating luminance set values corresponding to the first and second luminance control signals; and

generating a light emission control signal having a width corresponding to the second luminance control signal if the luminance set value corresponding to the second luminance control signal is lower than the luminance set value corresponding to the first luminance control signal.

17. An organic light emitting display device for displaying an image, the organic light emitting display device having a plurality of scan lines, a plurality of light emission control lines and a plurality of data lines, and comprising:

a display area including a plurality of pixels coupled to the scan lines, the light emission control lines and the data lines;

a scan driver electrically coupled to the display area through the scan lines and the light emission control lines;

a data driver electrically coupled to the display area through the data lines;

an optical sensor for generating an optical sensor signal corresponding to a brightness of an ambient light;

a first luminance control unit for outputting a first luminance control signal for adjusting a data signal of the image, applied to the data lines, in accordance with the optical sensor signal;

a second luminance control unit for outputting a second luminance control signal for adjusting light emission time of the pixels, in accordance with data of the image; and

**19**

a comparator/selector for comparing the first luminance control signal with the second luminance control signal to provide the first luminance control signal or the second luminance control signal to the data driver or the scan driver.

**18.** The organic light emitting display device of claim 17, wherein the first luminance control unit comprises a gamma correction unit for providing a gamma correction signal for adjusting the data signal to the comparator/selector.

**19.** The organic light emitting display device of claim 17, wherein the second luminance control unit comprises a luminance control signal generation unit for providing to the com-

**20**

parator/selector the second luminance control signal having a width information of a light emission control signal applied to the light emission control lines, in accordance with data of one frame of the image.

**20.** The organic light emitting display device of claim 17, wherein the comparator/selector is adapted to turn off the first luminance control unit or the second luminance control unit, in accordance with an extent to which a luminance of the display area is reduced.

\* \* \* \* \*

专利名称(译)	有机发光显示装置及其驱动方法		
公开(公告)号	<a href="#">US7952540</a>	公开(公告)日	2011-05-31
申请号	US11/861116	申请日	2007-09-25
[标]申请(专利权)人(译)	李旭		
申请(专利权)人(译)	李旭		
当前申请(专利权)人(译)	三星DISPLAY CO., LTD.		
[标]发明人	LEE WOOK		
发明人	LEE, WOOK		
IPC分类号	G09G3/30		
CPC分类号	G09G3/3225 G09G3/3266 G09G3/3291 G09G2300/0861 G09G2320/0276 G09G2360/16 G09G2320/0646 G09G2320/0673 G09G2330/021 G09G2330/028 G09G2360/144 G09G2320/064		
审查员(译)	王, 佳珍		
优先权	1020070011787 2007-02-05 KR		
其他公开文献	US20080186263A1		
外部链接	<a href="#">Espacenet</a> <a href="#">USPTO</a>		

摘要(译)

有机发光显示装置包括显示区域, 该显示区域包括与扫描, 发光控制和数据线耦合的像素; 扫描驱动器通过扫描和发光控制线电耦合到显示区域; 数据驱动器通过数据线电耦合到显示区域; 光学传感器, 用于产生对应于环境光亮度的传感器信号; 第一亮度控制单元, 用于输出第一亮度控制信号 ( $V_{c1}$ ), 用于根据传感器信号控制数据信号的经伽马校正的灰度级电压; 第二亮度控制单元, 用于输出第二亮度控制信号 ( $V_{c2}$ ), 用于根据一帧数据控制发光控制信号的宽度; 比较器/选择器, 用于比较第一和第二亮度控制信号, 以将它们中的一个输出到数据驱动器或扫描驱动器中。

